



European Siding System Ceiling Installation Guide

v20220408US



NewTechWood

CONTENTS

<u>Important Note</u>	3 - 5
<u>European Siding Parts</u>	6 - 8
<u>Under Construction</u>	9
<u>Furring Strips Installation</u>	10
<u>Expansion and Contraction Values Table</u>	11
<u>Locking the Siding Board</u>	12 - 14
European Siding System Ceiling Installation	
<u>-Framing</u>	15 - 17
<u>-Ceiling Board Installation</u>	18 - 23

NOTE: Click on the heading to enter the section directly

IMPORTANT Note:

Read All Sections Before You Start

For the most up to date information, please visit our website @ www.newtechwood.com

Prior to installing any composite siding system, it is recommended that you check with local building codes for any special requirements or restrictions. The diagrams and instructions outlined in this guide are for illustration purposes only and are not meant or implied to replace a licensed professional. Any construction or use of NewTechWood must be in accordance with all local zoning and/or building codes. The consumer assumes all risks and liability associated with the construction and use of this product.

Safety

When dealing with any type of construction project, it is necessary to wear appropriate safety equipment to avoid any risk of injuries. NewTechWood recommends, but is not limited to the following safety equipment, when handling, cutting, and installing NewTechWood: gloves, a respiratory protection, long sleeves, pants, and safety glasses.

Tools

Standard woodworking tools may be used. It is recommended that all blades have a carbide tip. Standard stainless steel or acceptable coated deck screws and nails are recommended.

Environment

A clean, smooth, flat, and strong surface is needed to install NewTechWood's products correctly. Please check with local building codes before ever installing any type of siding. If installation does not occur immediately, NewTechWood's products need to be put on a flat surface at all times. It should NEVER be put on a surface that is NOT flat.

Planning

Plan a layout for your siding before starting it to ensure the best possible looking siding for your project. Building codes and zoning ordinances generally apply to permanent structures, meaning anything that is anchored to the ground or attached to the house. So nearly every kind of siding requires permits and inspections from a local building department. We recommend drawing out a site plan of your proposed project that you intend to do to minimize errors and make your perfect Siding.

Pressure wash on a scrap piece of material before using a pressure washer on the profiles to make sure that your settings will not damage the Ultrashield coating.

Construction

NewTechWood UltraShield is NOT intended for use as columns, support posts, beams, joist stringers, support against a force, or other primary load-bearing members. NewTechWood must be supported by a code-compliant substructure. While NewTechWood products are great for retrofits, NewTechWood's products CANNOT be installed on existing siding boards.

Static

Static can also be more prevalent in areas that are of higher altitude because the humidity is lower. For these areas, be careful of using conducive objects such as metal railing and chairs as static shocks might occur more often. A potential way to lower the amount of static shocks occurring is to apply Staticide (www.aclstaticide.com) on your deck or use anti-static mats before doorways.

Ventilation

NewTechWood products CANNOT be directly installed onto a flat surface. It must be installed onto a substructure, so there is adequate and unobstructed air flow under the cladding to prevent excessive water absorption. A minimum of 1" (25mm) of continuous net free area under the siding surface is required for adequate ventilation on all siding, so air can circulate between adjacent members to promote drainage and drying.

Heat and Fire

Excessive heat on the surface of NewTechWood products from external sources such as but not limited to fire or reflection of focussing sunlight from some optical objects can potentially harm NewTechWood products. This extreme elevation of surface temperatures, which exceeds that of normal exposure, can possibly cause NewTechWood products to melt, sag, warp, discolor, increase expansion/contraction, and accelerate weathering.

Fasteners

When fastening NewTechWood's products all screws that are face fastened should always be driven in at a 90 degree angle to the siding surface. Toe nailing/screwing should never be done to the products. An extra furring strip should be added if a 90 degree angle cannot be driven into the board. All fasteners should be on their own independent furring strips, when two boards ends meet each other there must be a sister furring strip. The end of each board must sit on its own furring strip.

Use white chalk, straight boards, or string lines as templates for straight lines. NEVER USE COLORED CHALK. Colored chalk will permanently stain NewTechWood's products and are highly not recommended.

All nails/screws that are face fixed should always be stainless steel. Depending on the screws that you use when face fixing, there could be potential bulging or mushrooming. It is recommended to take care of these mushrooms/bulges by taking a rubber mallet and patting them down to give your siding a better look.

When choosing which screws/nails to use, always check first with your local home centers and hardware stores to see if they have screws that are engineered specifically for composite wood. These screws/nails will always work and give NewTechWood's products the best looking outcome, using other screws/nails that are not recommended for composite could potentially damage/harm the siding. If you are unsure which screw/nail to use, contact your manufacturer for more information.

Predrill

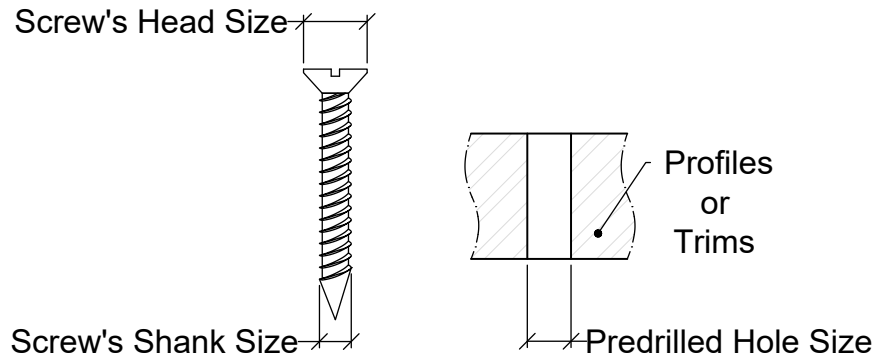

It is recommended to use the #8 pan head screw for face fixing the profiles and the trims onto the furring strips.

When face fixing, it is recommended to predrill the holes slightly larger on the profiles and the trims to allow for expansion and contraction response to temperature change, as shown in below diagram,



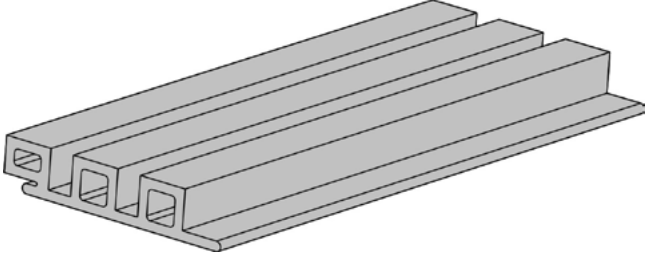
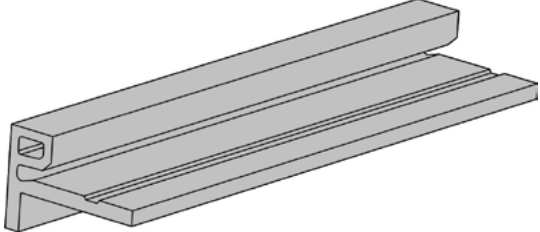

The predrilled hole size should be larger than the screw thread size, from 1/16" (1.5 mm) to 5/64" (2 mm). Moreover, the predrilled hole size should also be smaller than the screw head size, at least 5/64" (2 mm). A washer can be applied if the predrilled hole size is smaller than the screw head size below 5/64" (2 mm).

European Siding Parts

Product	Purpose	Part
AW-08	Used at every joint to fix each board to the furring strips	
T-7	Used on the last Siding Board installation	
UH46	European Siding Board	
UH50	F-Trim	

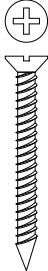
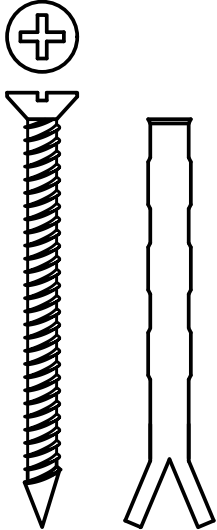
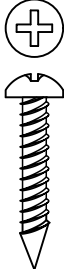

European Siding Screws (For Wood Furring Strip)

The table below shows the screws recommended to use for the installation, but not included.

Product	Purpose	Part
<p>#6 x 1 1/4" Stainless Steel SS304</p>	<p>Used when locking the board into the Clip (AW08)</p>	
<p>#8 x 3" Stainless Steel SS304 **depends on the thickness of your joists</p>	<p>Used when installing the furring strips onto the wall</p>	
<p>#8 x 1" Stainless Steel SS304 (Pan Head)</p>	<p>Used when installing the Clip (AW08) and the Rubber Stopper (T-7) onto the wood furring strips</p>	
<p>#8 x 1 1/4" Stainless Steel SS304 (Flat Head)</p>	<p>Used when installing the boards and the trims onto the wood furring strips</p>	

European Siding Screws (For Aluminum Furring Strip)

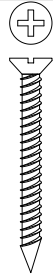
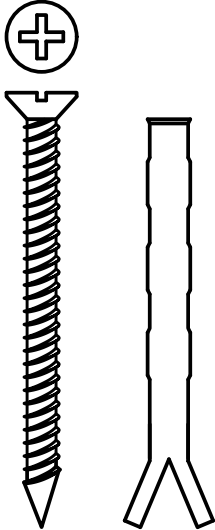
The table below shows the screws recommended to use for the installation, but not included.

Product	Purpose	Part
#6 x 1 1/4" Stainless Steel SS304	Used when locking the board into the Clip (AW08)	
#8 x 3" Stainless Steel SS304 **depends on the thickness of your joists	Used when installing the furring strips onto the wall	
#8 x 1" Stainless Steel SS410 (Pan Head)	Used when installing the Clip (AW08) and the Rubber Stopper (T-7) onto the aluminum furring strips	
#8 x 1 1/4" Stainless Steel SS410 (Flat Head)	Use when installing the boards and the trims onto the aluminum furring strips	

*Note: All screws are based on our recommendation and if the installation requires something different than what is shown, a professional should be consulted before installing.

The following installation guide will use the above screw sizes.

Under Construction

We recommend for the under construction aluminum or pressure treated wood furring strips. Each siding board needs to be supported by a furring strip NO MORE than 16" (406mm) from center to center. Extra care is required in order to provide sufficient joisting in and around obstacles such as windows, fascia's, soffits, guttering, ventilation points etc. Below is an example of the layers that would occur in a typical installation, but a licensed professional should always be consulted prior to any installation.

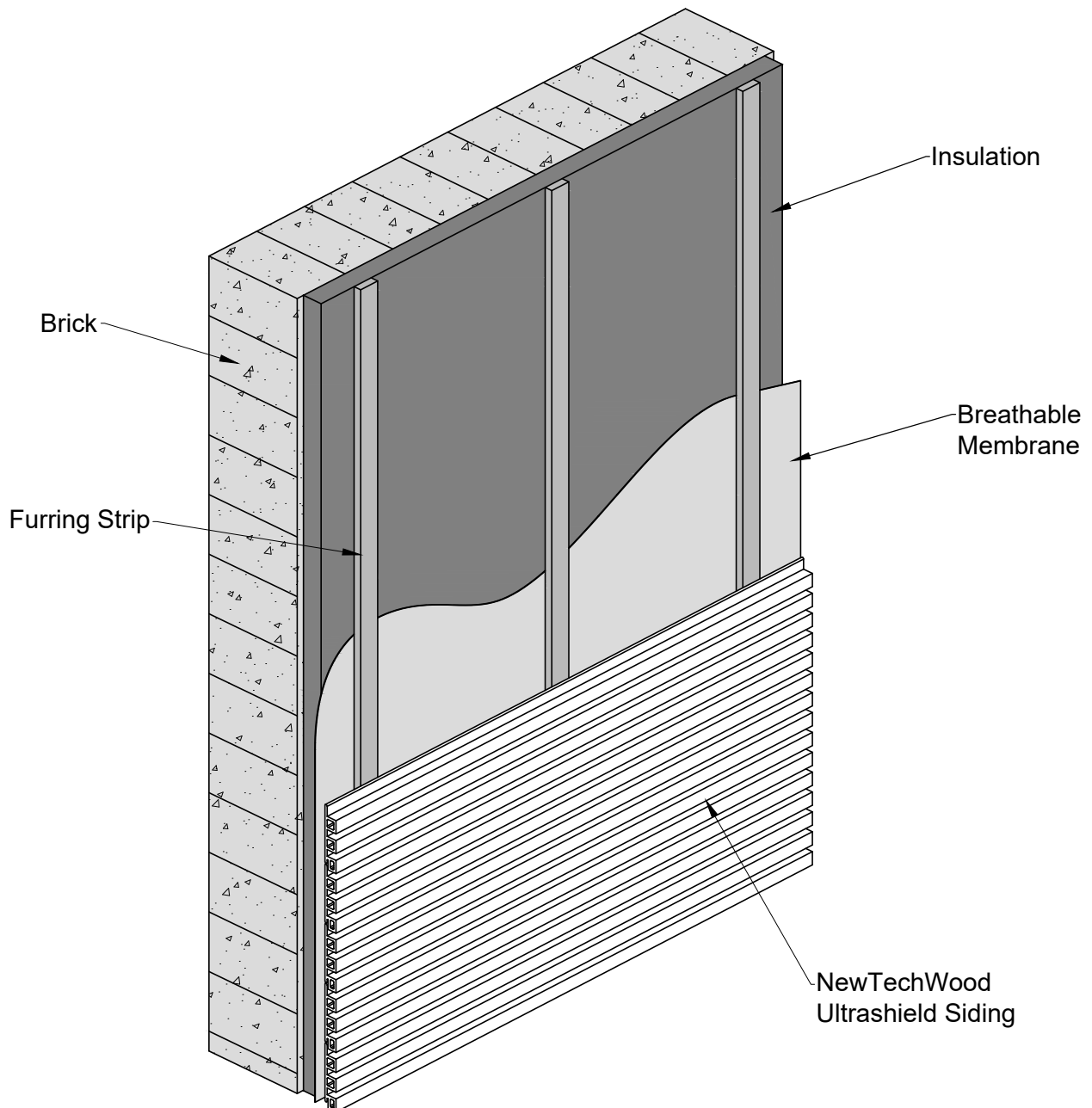

Furring Strips Installation

A building professional should be consulted regarding vapor barriers and insulation for your project. Where a vapor barrier is to be used, it should be a breathable type and must be positioned behind the furring strips. The furring strip needs to have a minimum thickness of 1" (25mm).

Wood furring strips should be fixed into position at a maximum of 12" (305mm) centers using a suitable A4 Stainless Steel Countersunk Wood/Masonry screw. All furring strips needs to be flat and leveled against the wall surface use shims if necessary.

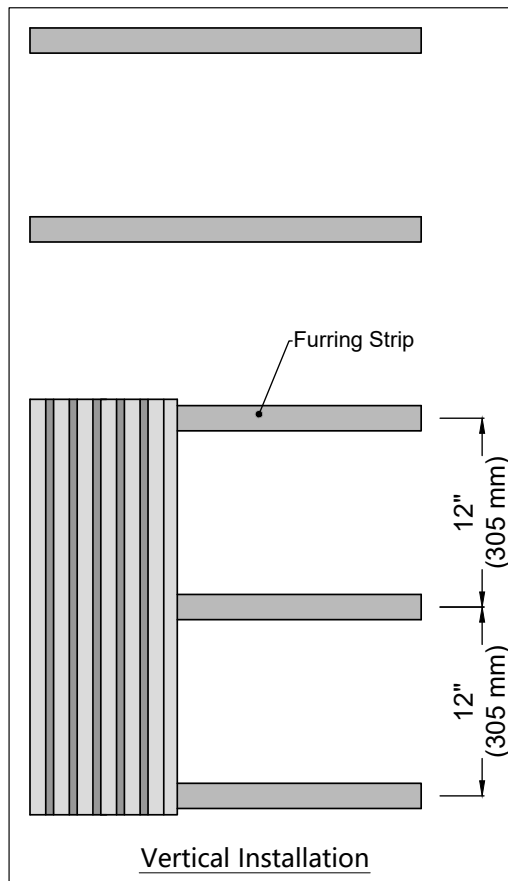
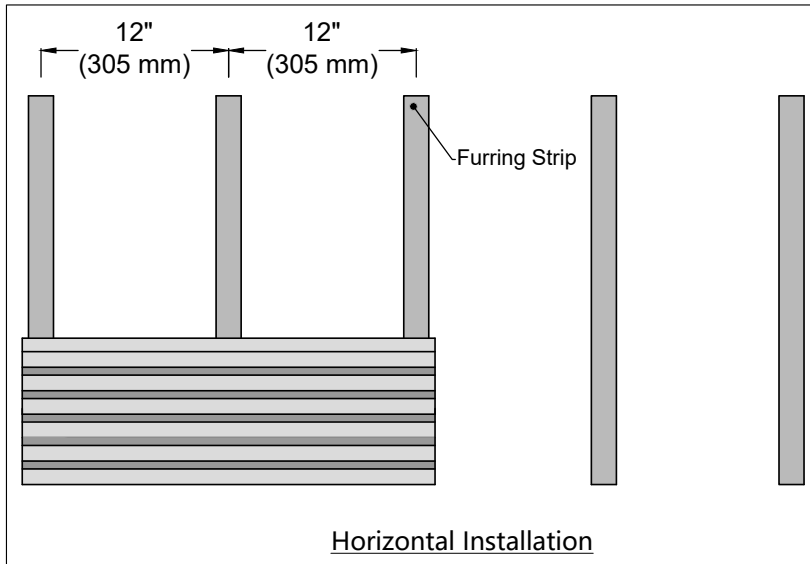

Expansion and Contraction Values

NewTechWood siding boards will experience expansion and contraction with changes in temperature. Expansion and contraction are most significant where extreme temperature changes occur. Fastening the deck planks according to the gapping requirements noted in the following table accommodates for this movement.

Expansion and Contraction table of values for North America, Canada, Australia and Asia

		Length (Feet)								
		3	8	9	10	12	13	16	18	
Installation Temperature (Farhenheit)	32	1/16	2/16	2/16	3/16	3/16	4/16	4/16	5/16	Gap (in)
	41	1/16	2/16	2/16	2/16	3/16	3/16	4/16	4/16	
	50	1/16	2/16	2/16	2/16	2/16	3/16	3/16	3/16	
	59	1/16	1/16	1/16	2/16	2/16	2/16	2/16	3/16	
	68	3/64	1/16	1/16	1/16	1/16	2/16	2/16	2/16	
	77	3/64	1/16	1/16	1/16	1/16	1/16	1/16	1/16	
	86	3/64	3/64	3/64	3/64	3/64	1/16	1/16	1/16	

Note: If you are still unsure of what gapping to use, contact the manufacturer and they will give you the correct gapping requirements based on your environment and area.

Locking the Siding Board

Since the composite wood must allow for expansion and contraction due to temperature change, the board must be locked at one fixed point but only one point to allow the remaining board to expand and contract freely. In the case there is a need to lock the board, Clip (AW08) comes with a separate hole.

It is important that **DO NOT LOCK** any other clips for the same board.

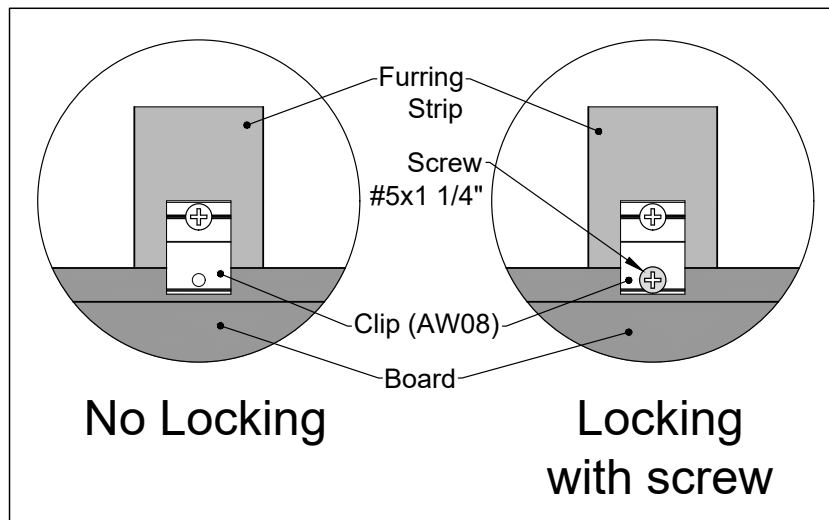

- Ceiling Installation - Aluminum Furring Strips

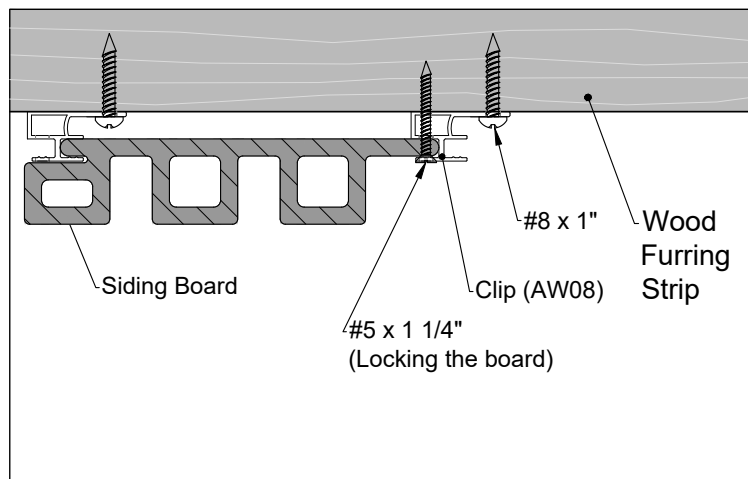

- Ceiling Installation - Wood Furring Strips

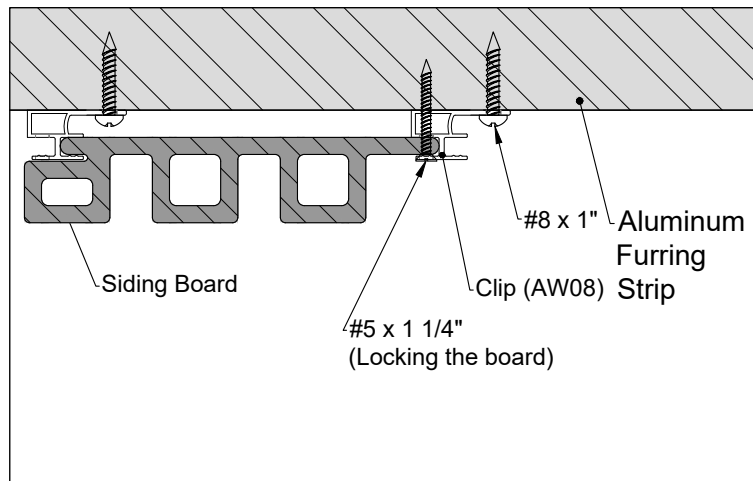

When installing the ceiling, it is required to lock the Clip (AW08) at the middle of the board, as shown in **Diagram A1**.

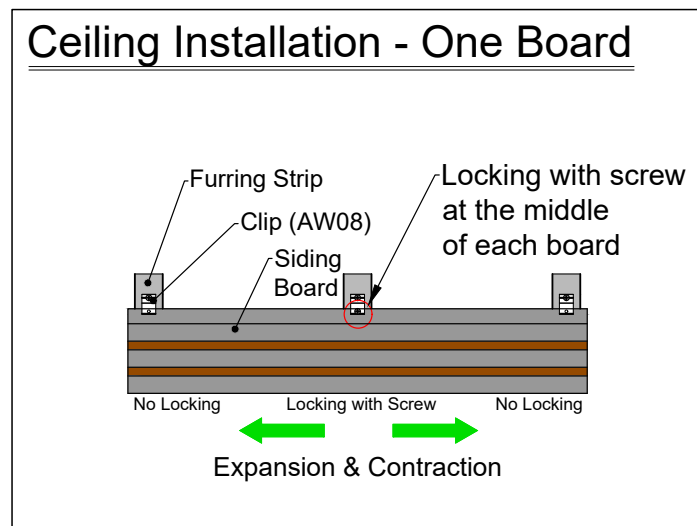
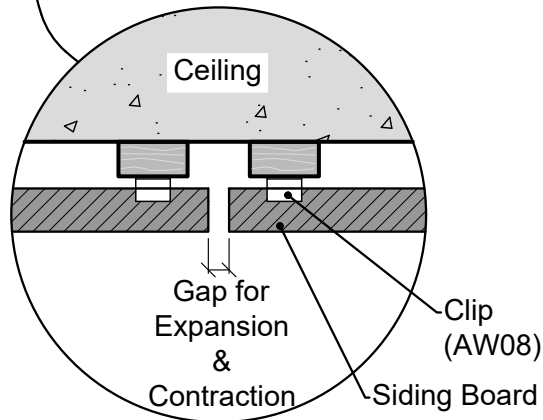
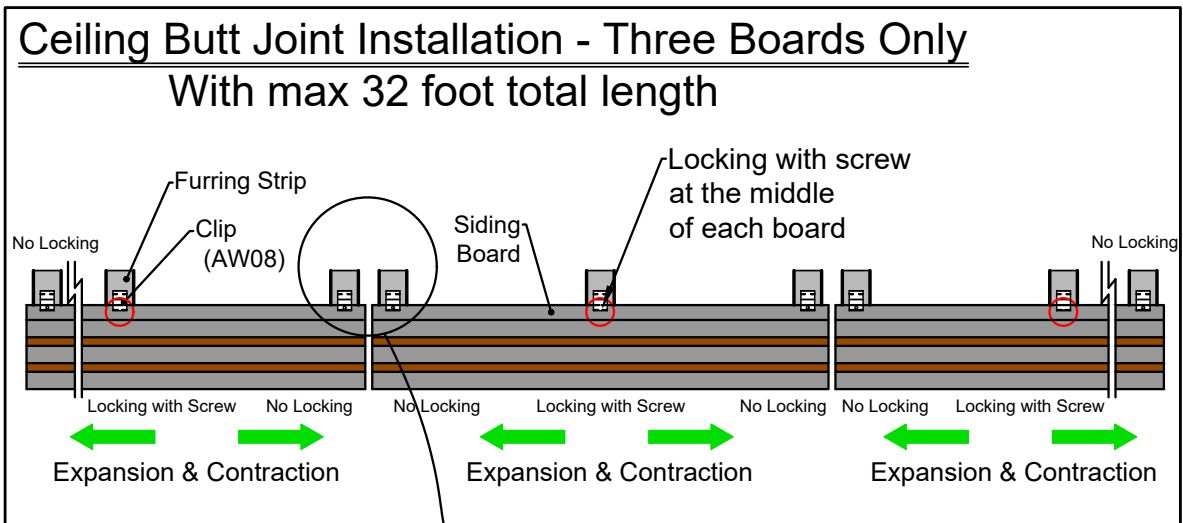
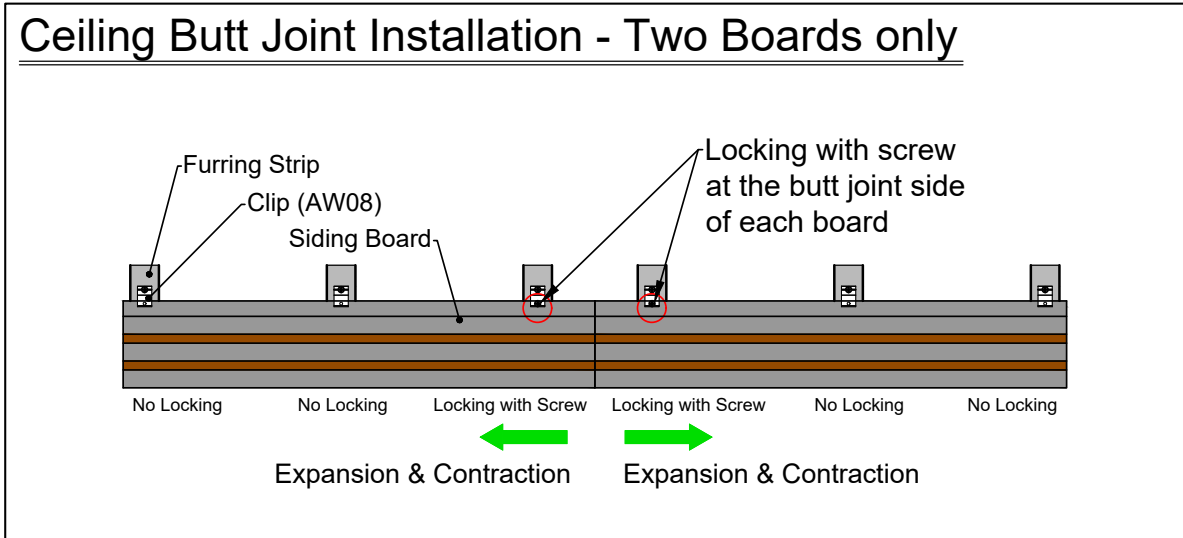

Diagram A1

- Ceiling Butt Joint Installation -



Ceiling Installation

1 Framing

Fix the furring strips onto the ceiling where you intend to install the board. It is recommended to apply the furring strip span of not more than 12" (300mm), as shown in **Diagram 1**.

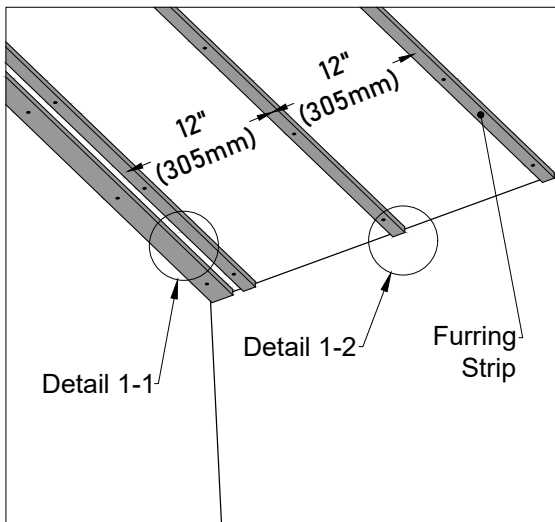
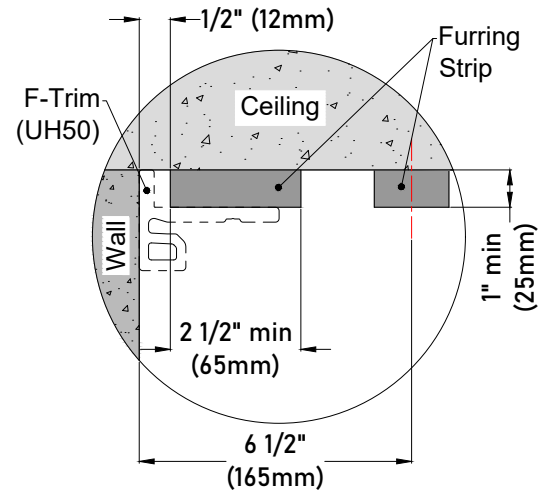

Diagram 1

Please Note:

1. It is recommended to use the furring strip in the thickness of min 1" (25mm).
2. A gap of 1/2" should be left between the furring strip and the wall to allow the F-Trim UH-50 to be correctly placed without interfering with the furring strips, as shown in **Detail 1-1** and **Detail 1-2**.



Detail 1-1

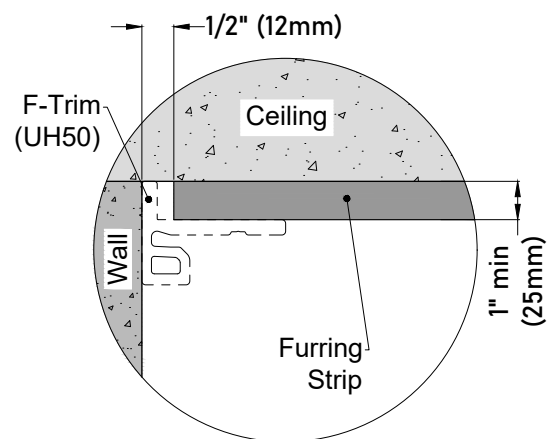

Detail 1-2

- 2 Miter cut the Trim UH50 according to the wall corner's angle for adjoining the trims in the wall corner, as shown in **Diagram 2**

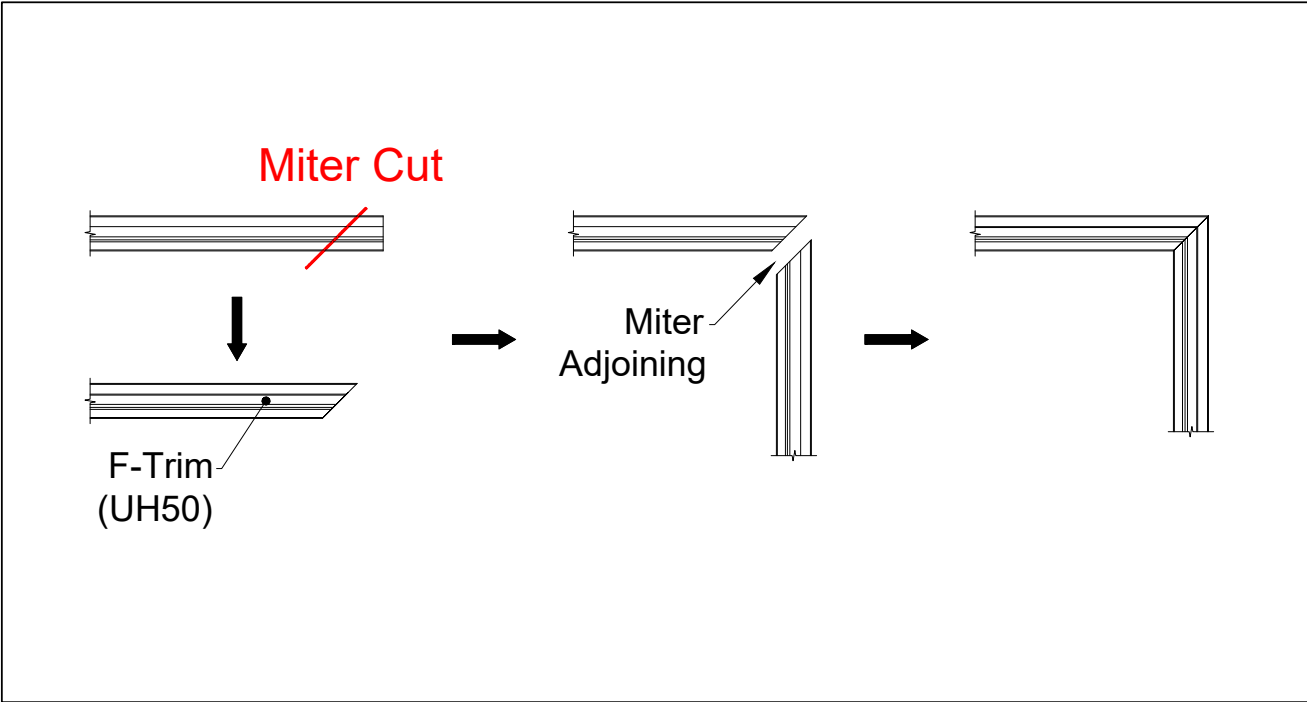

Diagram 2

- 3 Put the miter cut trims in place next to the long side of the furring strip and fix them onto the furring strip with screws, as shown in **Diagram 3** and **Detail 3-1**.

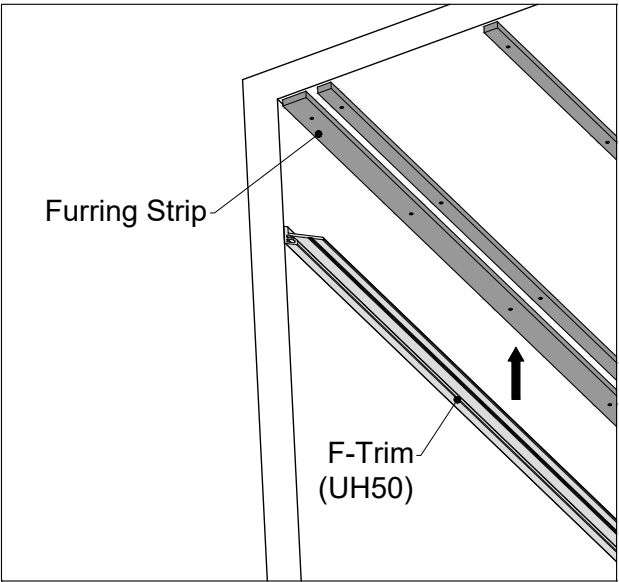
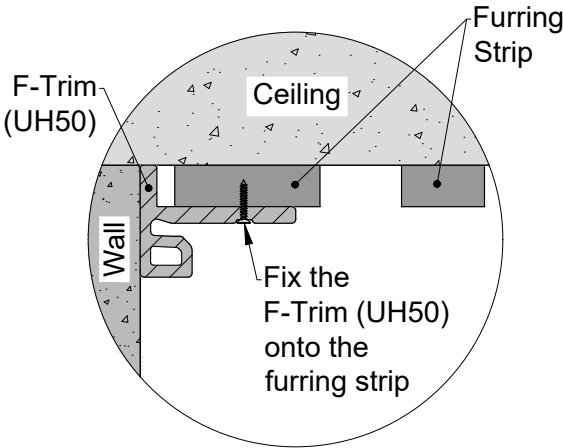
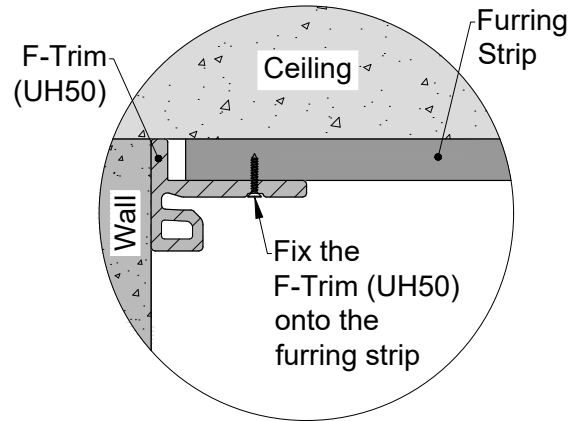
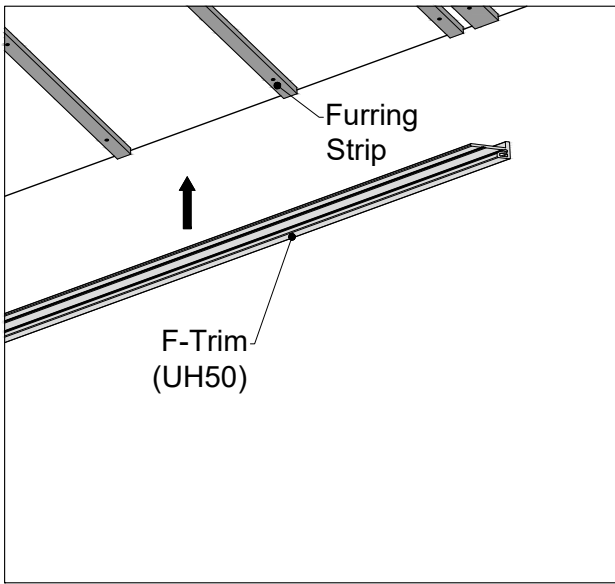

Diagram 3



Detail 3-1

- 4 Then put the miter cut trims in place next to the end side of the furring strip and fix them onto the furring strip with screws, as shown in **Diagram 4** and **Detail 4-1**.



Detail 4-1

Diagram 4

- 5 Diagram 5 presents the final appearance after completing the installation of the trim.

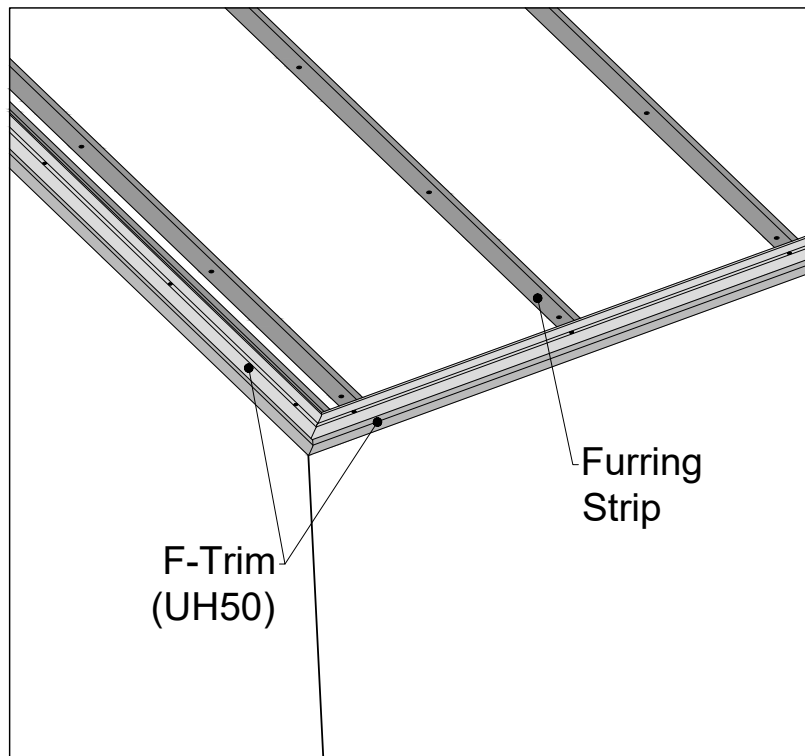

Diagram 5

6 Ceiling board installation

Put the first Siding Board (UH46) over the F-Trim (UH50), as shown in **Diagram 6** and **Detail 6-1**.

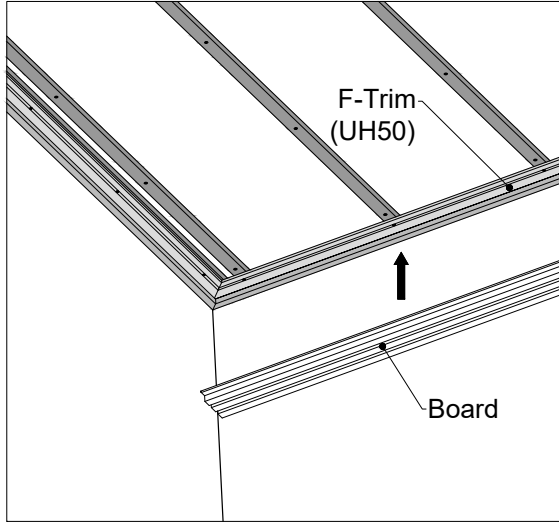
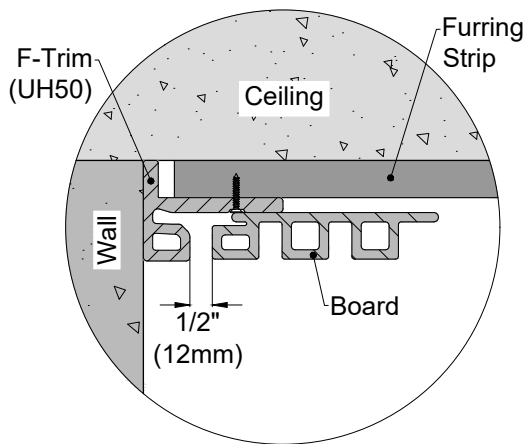

Diagram 6



Detail 6-1

7 Face fix it to the furring strips with screws, as shown in **Diagram 7** and **Detail 7-1**.

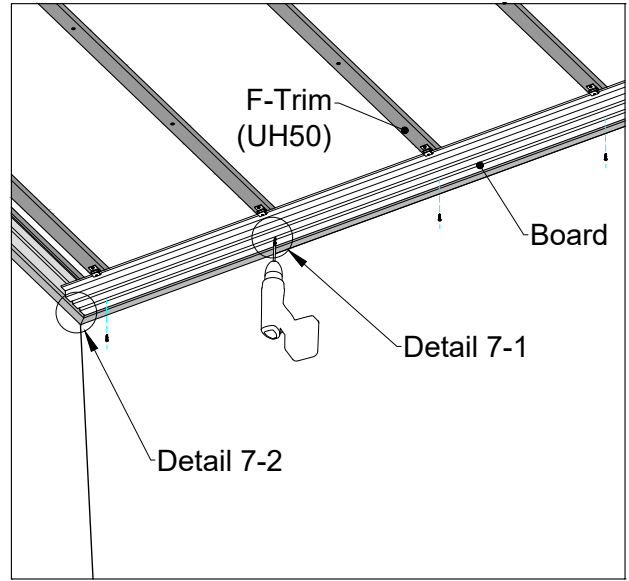
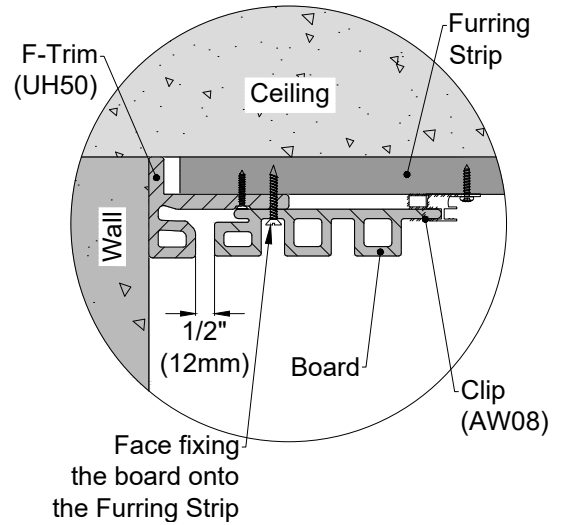

Diagram 7



Detail 7-1

Please Note:

1. The gap between the board and the F-Trim (UH50) should be left to allow the board from expansion and contraction to avoid warping and buckling, as shown in **Detail 7-2**. Please select the appropriate gap value according to the **"Expansion and Contraction Values Table"** on **page 11** of this installation guide.

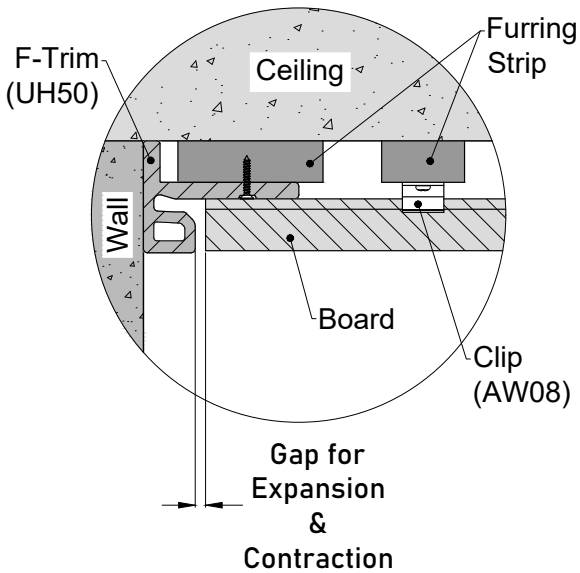

Detail 7-2

8 Since the composite wood must allow for expansion and contraction due to temperature change, the board must be **locked at one fixed point but only one point** to allow the remaining board to move freely. When installing horizontally, it is required to **lock the Clip (AW08) at the middle of each board**, as shown in *Diagram 8* and *Detail 8-1*.

DO NOT LOCK any other Clip (AW08) for the same board.

Please review *page 12*, **"Locking the Siding Board"** of this installation guide for further information.

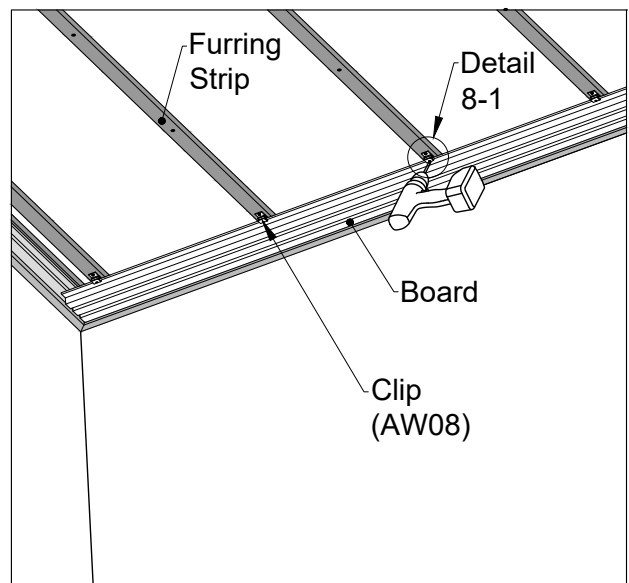
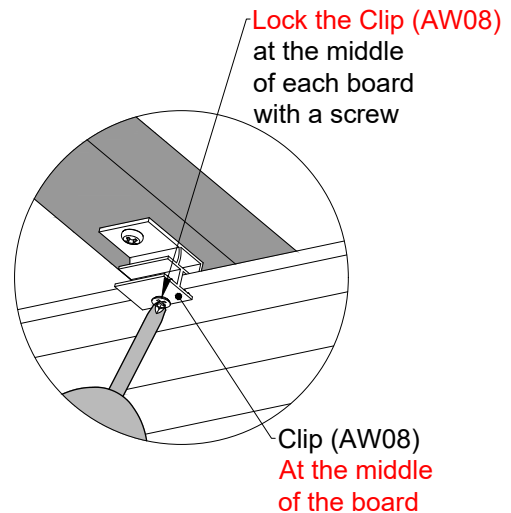

Diagram 8



Detail 8-1

- 9** Put the next Siding Board (UH46) in place and slide it inside the Clip (AW08), as shown in **Diagram 9** and **Detail 9-1**. Then fasten it to the furring strips with Clip (AW08) repeat the same procedure as the installation **Step 8**.

Please Note:

1. The gap between the board and the trim should be left to allow the board from expansion and contraction to avoid warping and buckling, as shown in **Detail 7-2**. Please select the appropriate gap value according to the **"Expansion and Contraction Values Table"** on **page 11** of this installation guide.

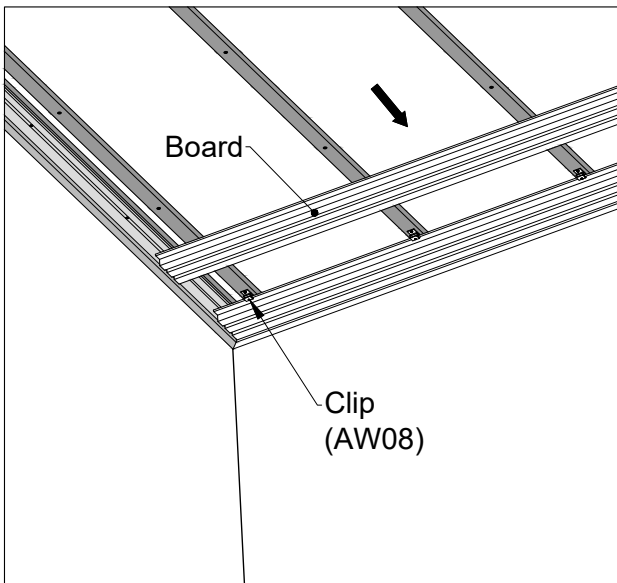
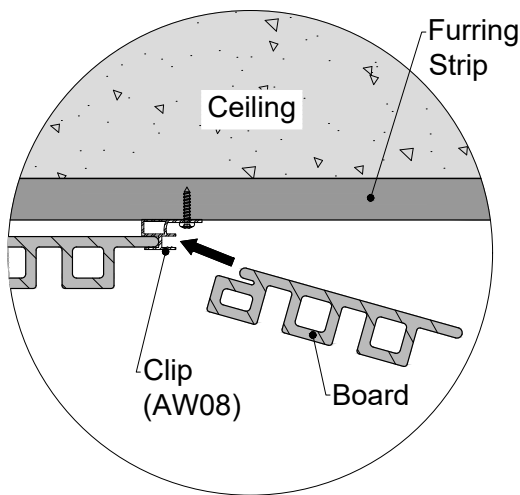

Diagram 9



Detail 9-1

- 10** When you are at the Siding's last board, measure the distance between the F-Trim (UH50) and the Clip (AW08), as shown in **Diagram 10** and **Detail 10-1**.

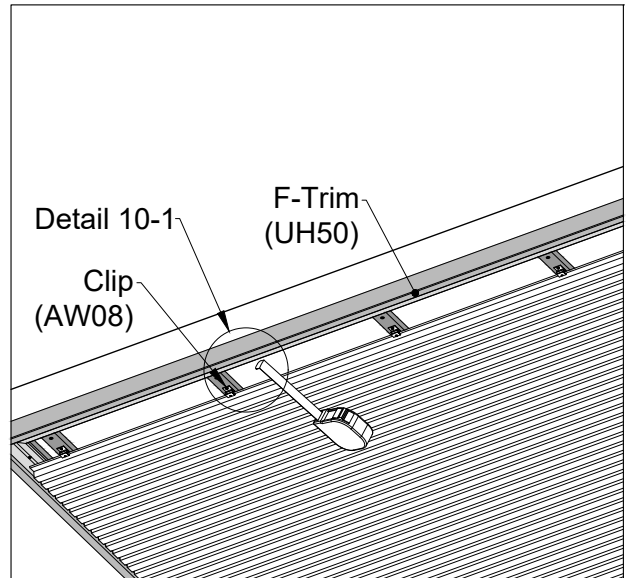
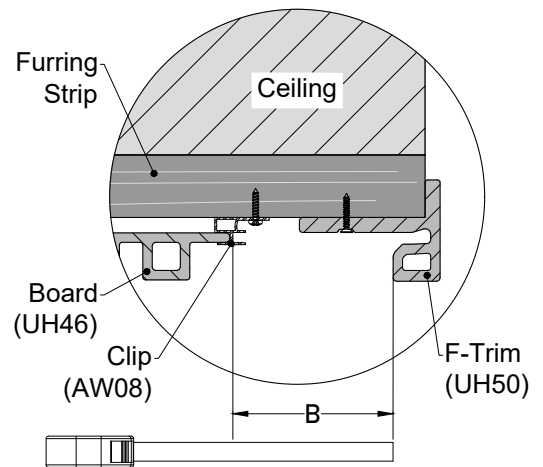

Diagram 10



Detail 10-1

- 11** Refer to the measurement to determine the rip point to get the appropriate gap between the tim, as shown in **Diagram 11** and **Detail 11-1**.

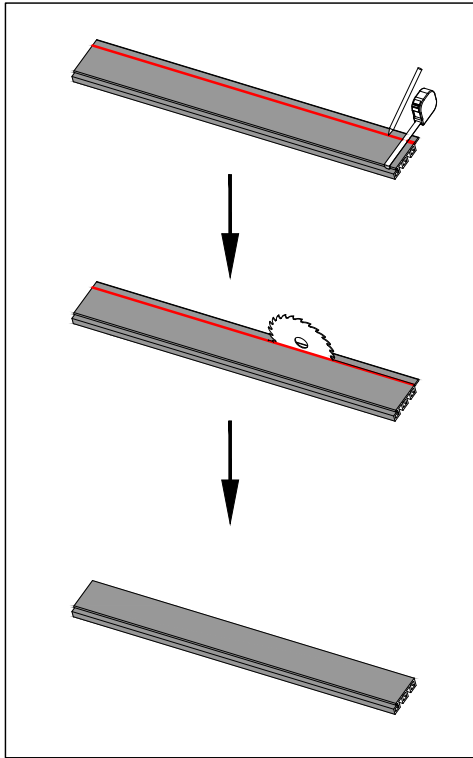
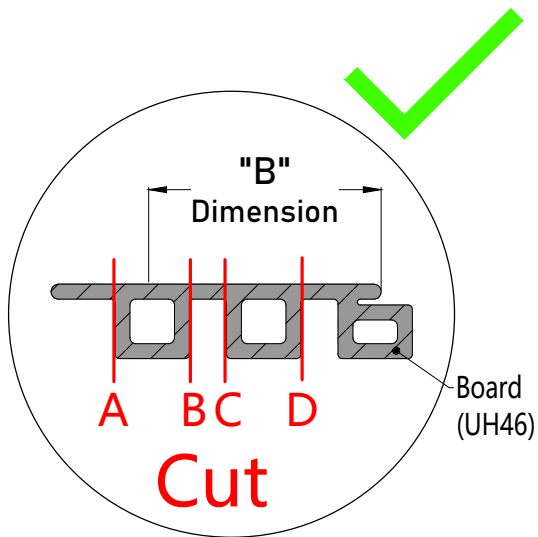

Diagram 11



Detail 11-1

Please Note:

It is not recommended to rip the board on the raised portion, as shown in **Detail 11-2**.

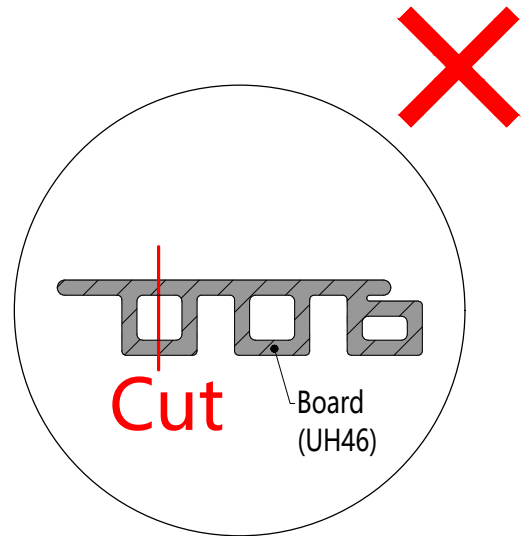

Detail 11-2

Detail 11-3 and **11-4** present the installation details when the rip point is at A or B.

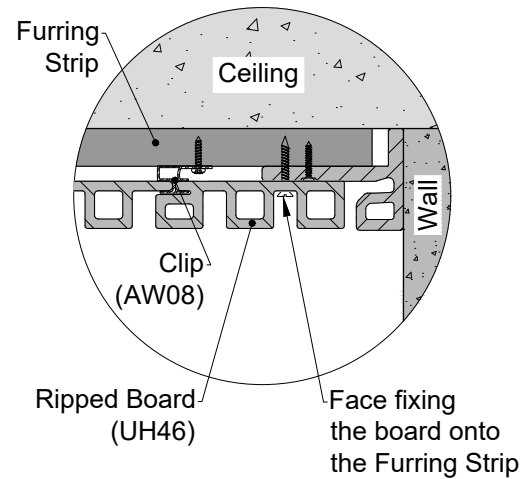

Detail 11-3

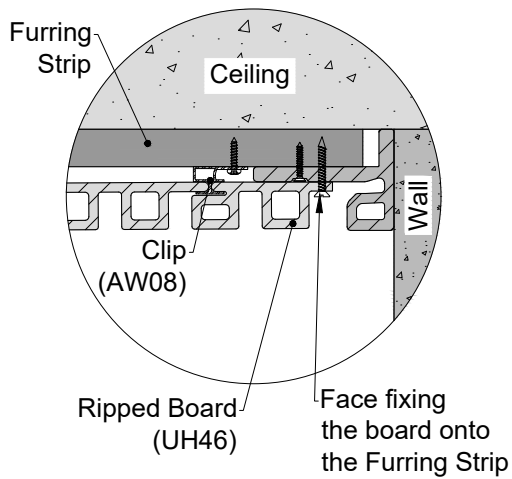

Detail 11-4

When the rip point occurs at C or D, use a rubber stopper T-7 instead the Clip AW08 and face fix the boards, as shown in **Detail 11-5** and **11-6**.

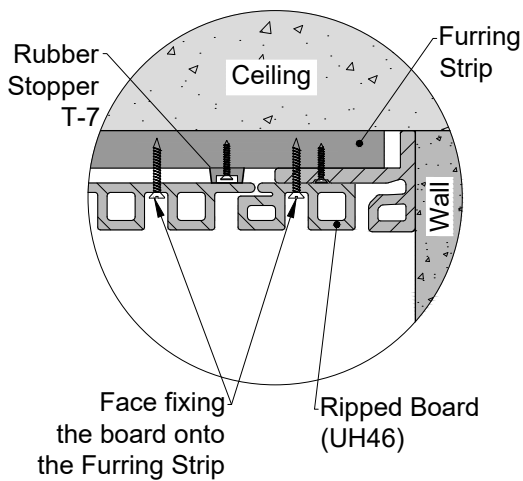

Detail 11-5

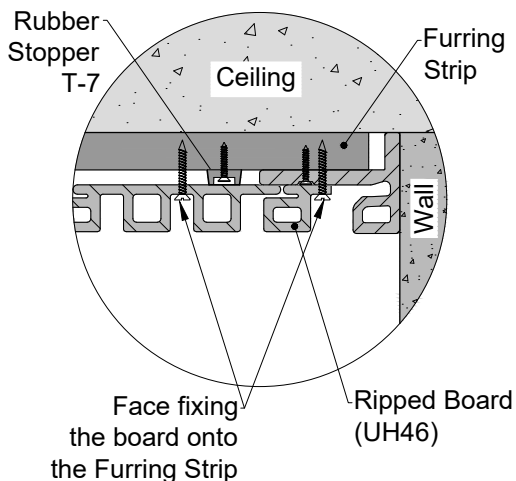

Detail 11-6

12 Put the ripped Siding Board (UH46) over the F-Trim (UH50) and pre-drill the screw holes before installation, as shown in **Diagram 12** and **Detail 12-1**.

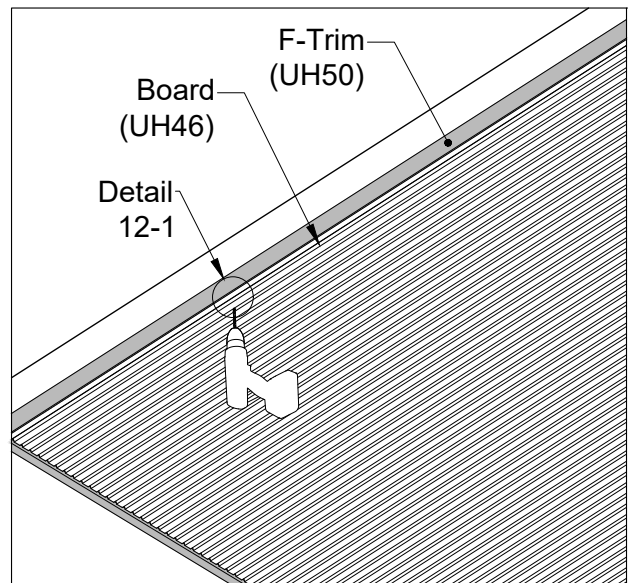
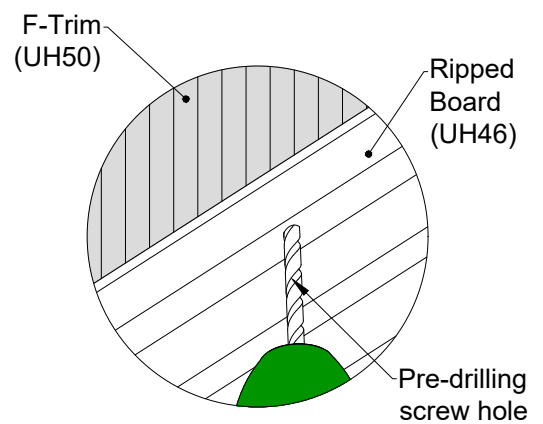

Diagram 12



Detail 12-1

- 13** Face fix the ripped Siding Board (UH46) onto each furring strip over the F-Trim (UH50) along the length of the board with screws, as shown in **Diagram 13** and **Detail 13-1**.

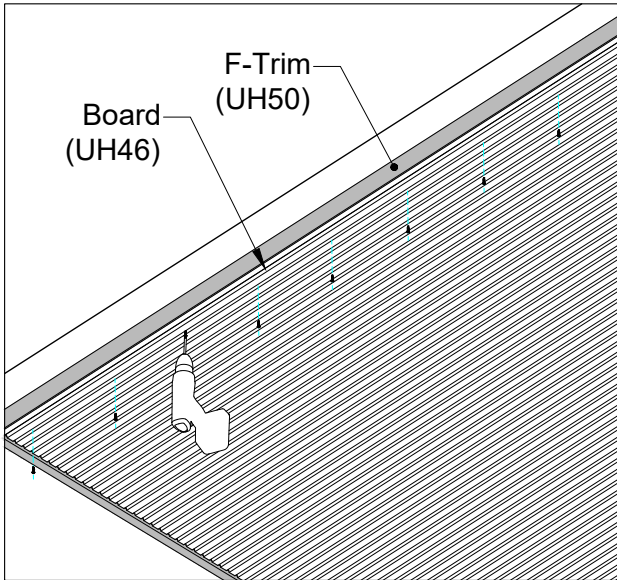
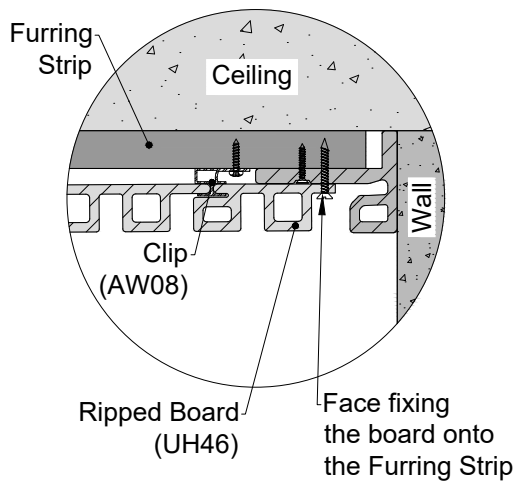

Diagram 13



Detail 13-1

- 14** **Diagram 14** presents the final appearance after completing the installation.

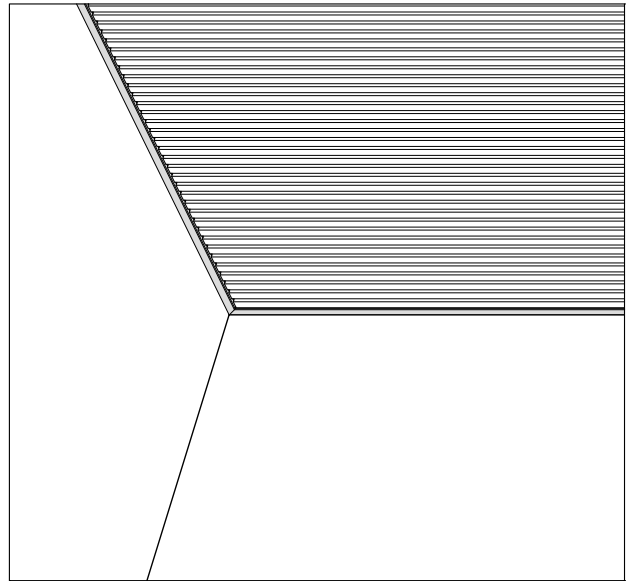

Diagram 14



European Siding System Ceiling Installation Guide

v20220408US

©2022 Newtechwood Corporation

NewTechWood® is a registered trademark of Newtechwood Corporation.

To obtain a copy of the most current version of this installation guide,

visit us online at www.newtechwood.com



NewTechWood